

**TECHNICAL SPECIFICATION**  
**ASSEMBLY MANUAL**  
**Wind speed display board**  
**T3-S275**



PRODUCT SUPPORT:  
Paweł Ciechanowski  
[p.ciechanowski@polanik.com](mailto:p.ciechanowski@polanik.com)

File: 2016-06-16  
© 2016 Polanik

## I. Description

The display board T3-S275 is used during the athletics competition of long jump, triple jump and running.

Characteristics:

**an innovative construction** – its elements are easy to assemble and do not take up much space during transport or storing,

**it's easy-to-operate** – fast assembly and comfortable +/- sign,

**durability and high-quality implementation** – bearing elements and +/- sign are powder painted and made from steel, other items and digit panels are made from top-quality materials resistant to unfavourable weather conditions.

**It is also possible to exchange** worn-out parts.



## II. Technical specification and dimensions [mm]

<b>Code</b>	T3-S275
<b>Type</b>	2-digit, -/+ sign
<b>Number of items</b>	3
<b>Board</b>	waterproof board from 10 mm foamed PVC
<b>Digital units</b>	plastic, easy to exchange, hand switched
<b>Construction</b>	steel, powder painted; two-segment post with synthetic connector, rotation 360°, blocked in desired position with adjusting screw
<b>Base</b>	steel, powder painted
<b>Weight [kg]</b>	~20

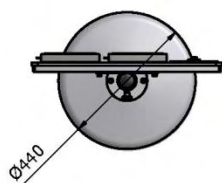
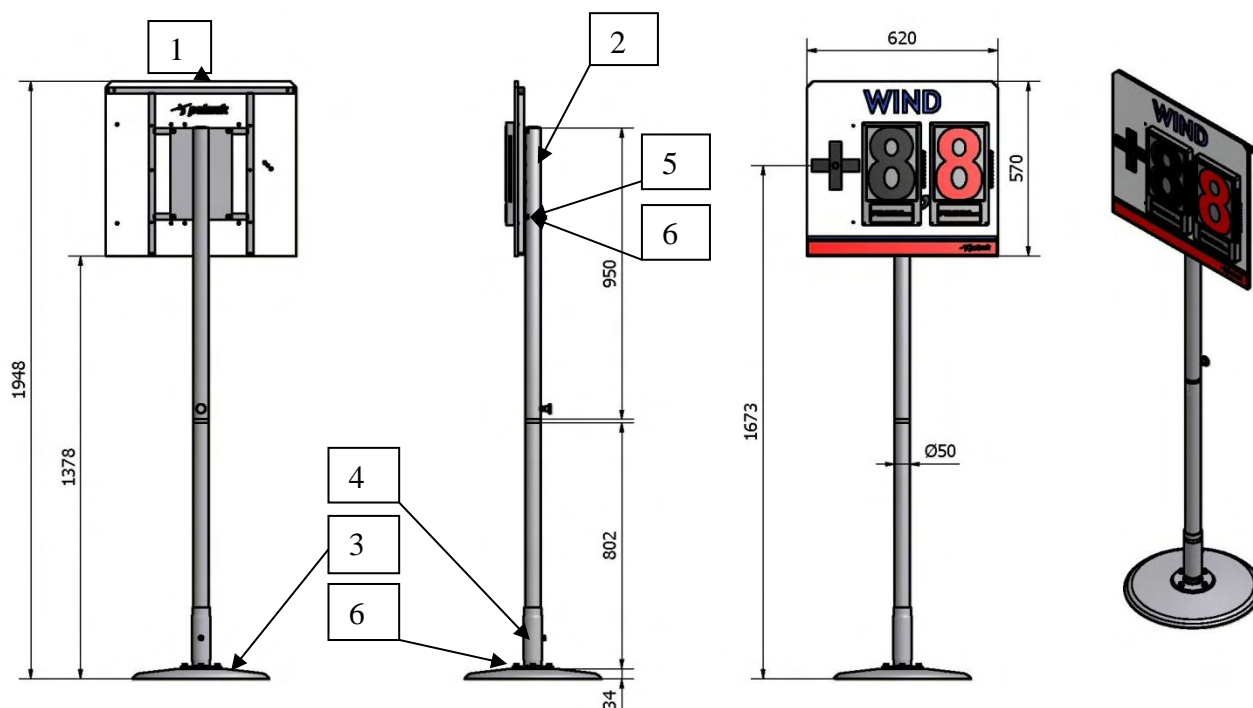

Item	Description
1	Wind speed display board with bracket and digital plastic units
2	Backing plate with rotary tube
3	Round base
4	Clamping ring with constant tube kpl.
5	Washer
6	Cap screw with hexagonal socket

## III. Parts' description and assembly

The performance board T3-S275 is delivered partially disassembled and it contains all the elements.

Assembly starts with setting the base (item 3). Then screw down the clamping ring with the constant tube (item 4) to the base, using screws and washers (item 5,6). Afterwards put backing plate with rotary tube (item 2) and factory installed subassembly of wind speed display board with bracket and digital plastic units (item 1) on the clamping ring with the constant tube (item 5).

The performance T3-S275 board is ready to use.

### III. Operating and maintenance

**ATTENTION! The digital units are equipped with self-barking holders for digit switching. To avoid failures during operating, It is not recommended to switch more than 2-3 digits in one panel simultaneously. Keep the board away rain and moisture – if the water gets inside the digital units, it may cause the plastic elements getting stuck together and make switching of the digits impossible.**

Move the display board to a roofed place after every training and competition. Clean using a moist cloth with addition of a delicate detergent. If the protective covering damages, use anticorrosive paint.



### IV. Packing and transport

The product is wrapped with foil and packed into a cardboard box (dim. 1130 x 640 x 150 [mm]).

Even the best technical solutions cannot substitute for common sense. The usage of the product must take place under the supervision of qualified coaches. The producer shall not be liable for any incidents caused by the improper assembly or its misuse. The producer reserves the right to introduce without warning changes in product constructions and colours.